

WILROY™

HYDRAULICALLY ACTUATED DIAPHRAGM PUMP

INSTALLATION, OPERATION, AND MAINTENANCE MANUAL



WILLIAMS
MILTON ROY

WILROY™

SERIES OF METERING PUMPS

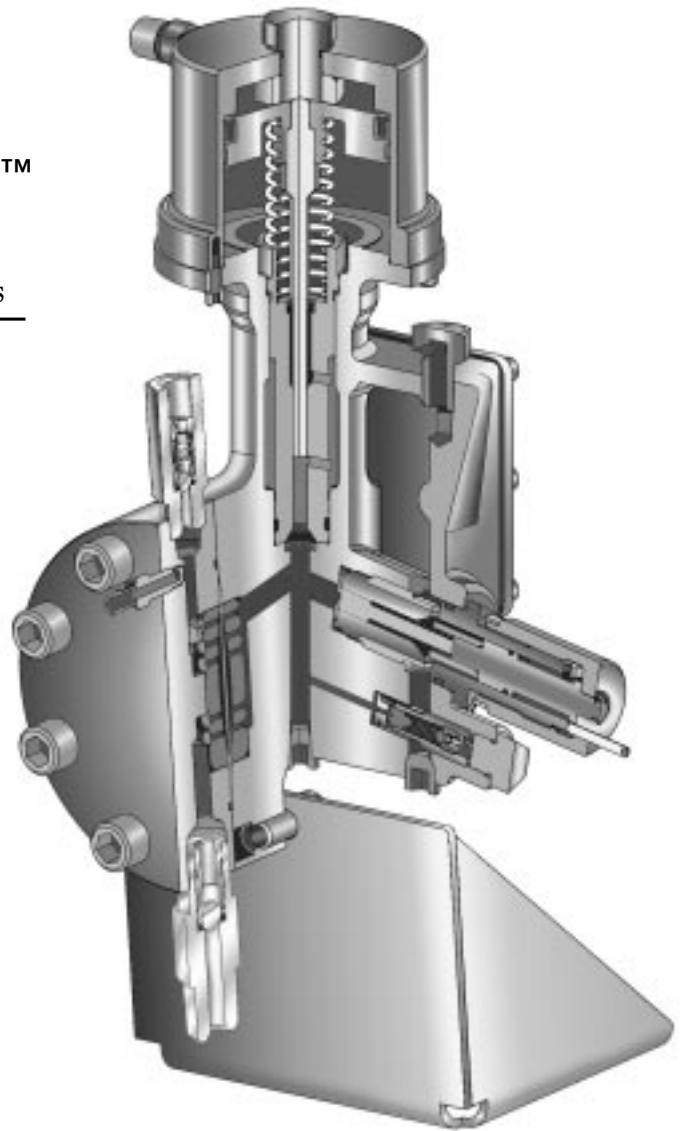

PART MODEL NUMBER

WRA 1 - 11 2M NN SE BB

WRA 1: 316 SS
Model Construction

NN: None
11: MK XIII
Control Method

2N: .250" plunger, no stroke adjuster
5N: .500" plunger, no stroke adjuster
2M: .250" plunger with 316 SS micrometer knob
5M: .500" plunger with 316 SS micrometer knob
Plunger Configuration

Base Selection
NN: None
BB: Base

Connections
SE: 1/4" NPT(F) Discharge
 1/2" NPT(M) Suction

Diaphragm Rupture Detection
NN: None
C5: Rupture Detection Bracket & Gauge
SN: Rupture Detection Gauge & Nema 4 switch
S7: Rupture Detection Gauge & Nema 7 switch

TABLE OF CONTENTS

Section	Description	Page
	Pump Model Number	Inside Cover
1.0	FUNCTIONAL DESCRIPTION	1
	1.1 Physical Description	1
	1.2 Capabilities and Specifications	1
	1.3 General Operating Sequence	3
2.0	INSTALLATION OF PUMP AND CONTROLLER	3
	2.1 General	3
	2.2 Pump Mounting	4
	2.3 Typical Installation	4
	2.4 Supply Reservoir	4
	2.5 Relief Valve	4
3.0	START UP, OPERATION & SHUTDOWN	4
	3.1 General	4
	3.2 Startup	5
	3.3 Operation	5
	3.4 Shutdown and Storage	6
4.0	MAINTENANCE	6
	4.1 General	6
	4.2 Disassembly and Assembly	6
	4.3 Preventive Maintenance	12
	4.4 Troubleshooting	12
5.0	REPAIR KIT AND CONVERSION KIT ORDERING REFERENCE	15
	5.1 Repair Kit	15
	5.2 Conversion Kit	15
6.0	LIMITED WARRANTY	15

SECTION 1.0: FUNCTIONAL DESCRIPTION

1.1 PHYSICAL DESCRIPTION

A drawing of the Wilroy™ pump and Mark XIIA controller, with relevant dimensions, is seen in Figure 1. The pump is powered by compressed air/gas. The air/gas must first be controlled by the Mark XIIA controller or a solenoid valve in order to provide the pump with regulated bursts of air/gas.

1.1.1 Pump

The Wilroy™ pump comes with either a 1/4" (Wilroy™ 2M) or 1/2" (Wilroy™ 5M) plunger. Operated by controller or solenoid, the pump is manufactured with a totally sealed hydraulic chamber, removable bore cartridge and integral air bleed mechanism. Along with a serviceable diaphragm, the pump's design assures relatively simple maintenance and operation.

The piston face area where the air/gas pressure is applied is much greater than the plunger face area, which works against the pressure of the process fluid. This area ratio, called the **amplification ratio**, allows the pump to work against process fluid pressures much greater than the air/gas supply pressure.

Note: process pressure + 200 psi / required air supply = amplification ratio

1.1.2 Mark XIIA Controller

The MK XIIA Controller consists of an upper and a lower chamber, separated by a sliding spool and flexible diaphragms. A capillary tube, controlled by a needle valve, transfers the air/gas supply to the pump from the lower to the upper chamber. When the sliding spool is in its highest position, a pilot plug closes a vent and opens the supply air/gas to the pump. When the spool is in its lowest position, the pilot plug prevents the supply air/gas from entering the pump, and opens the air/gas vent to let it exhaust the pump. The spool then returns to its highest position to repeat the cycle. An illustration of the controller is shown in Figure 2.

1.1.3 Solenoid Valve

The pumps can be automated by replacing the controller with a 3-way electro-pneumatic solenoid valve. The solenoid valve can be cycled in order to achieve the desired pump output. Flow tracking can be accomplished by having a flowmeter or pH meter signal interpreted by our WPC9001 or a PLC. The typical arrangement for a WPC-9001 installation is shown in Figure 3.

1.2 CAPABILITIES AND SPECIFICATIONS

1.2.1 Pump

The maximum performance characteristics of the Wilroy™ pumps can be found in Table 1. This table lists the maximum flow rate, which is only reached when the discharge pressure is at a minimum. The maximum discharge pressure is also listed, but there is a significant reduction in flow rate at higher discharge pressures. For the complete flow and pressure characteristics refer to figures 4 and 5.

1.2.1.1 Pump Performance

See Pump Performance Graphs (page 3)

1.2.1.2 Pump Hydraulic Fluid

For optimum performance, the Wilroy™ pump should be filled with one of the following oils: Mobil SHC-524, Mobil DTE 13M or an appropriate equivalent.

1.2.2 Controller

The controller will operate with air or any gas, such as carbon dioxide, nitrogen or natural gas. **WARNING: TO PREVENT INJURY, MAKE SURE THAT ANY FLAMMABLE GAS SUCH AS NATURAL GAS IS PROPERLY VENTED FOR SAFETY.** **CAUTION: If the gas could possibly damage the standard elastomeric material, please contact your Williams distributor or Milton Roy company for advice.** To increase the process fluid flow rate, two or more pumps can be multiplexed: their inlets and outlets connected in parallel.



Figure 1: Physical Specifications - Dimensions in inches [mm]

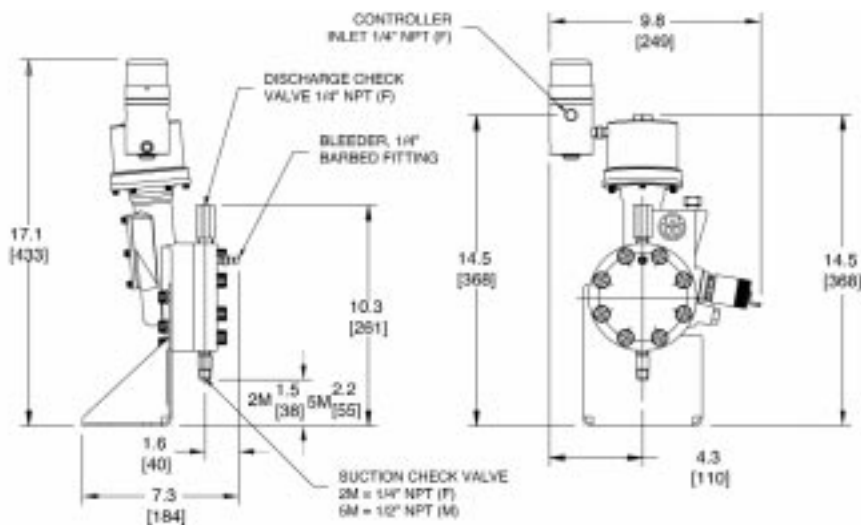
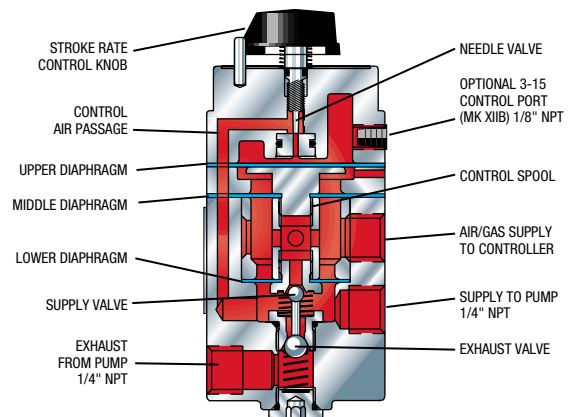

Figure 2: Oscillamatic® Mark XIIA Controller



1.2.2.1 Controller Supply Pressure

The controller will operate with a maximum supply pressure of 100 psi (6.9 bar) and a minimum supply pressure of 35 psi (2.4 bar). In order to achieve the maximum discharge pressure, the air/gas supply pressure must be set at 100 psi (6.9 bar).

CAUTION: To prevent damage to the controller, always use a regulator between the supply and the controller when the air/gas supply pressure is more than the maximum rating of your controller.

1.3 GENERAL OPERATING SEQUENCE

1.3.1 Mark XIIA Controller

The spool spring forces the spool upward to its highest position and unseats the top of the pilot plug from the upper seat. The exhaust spring forces the pilot plug upward and seats it on the lower seat. This blocks the air/gas exhaust port.

When high pressure air/gas enters the supply port, it passes around and through the spool and past the open upper seat to the motor cylinder port.

High pressure air/gas passes through the control passage in the controller, past the valve stem, and into the valve body upper chamber which causes pressure to build

up in the chamber. Because the surface area of the upper U-cup diaphragm is much larger than that of the middle U-cup diaphragm, the downward force on the spool is greater than the upward force.

This pressure pushes the spool down until the pilot plug seats itself on the upper valve seat, shutting off the air/gas supply.

As the spool continues to move down, it pushes the pilot plug until the plug is unseated from the lower valve seat and allows the air/gas to exhaust through the lower valve from both the motor cylinder and the valve body volume chamber. When the pressure in the chamber is low enough, the spool spring starts pushing the spool upward. The exhaust spring pushes the pilot plug upward, and the controller returns to its initial position.

1.3.2 Pump Motor (Air Chamber)

The motor forces the piston plunger to move alternately into and out of the pump chamber. When the controller sends the supply air/gas into the motor chamber through the nipple connector, the pressure on the piston and diaphragm overcomes the combined force of the process fluid pressure on the piston plunger and plunger return spring, and pushes the plunger into the fluid chamber. When the external controller exhausts the air/gas, the piston

plunger return spring and process fluid pressure push the piston plunger out of the fluid chamber.

1.3.3 Pump (Liquid End)

The pump operating cycle consists of fluid being discharged and suctioned into the liquid end. During discharge, the piston plunger moves into the pump fluid chamber, decreasing the volume of the chamber and raising the pressure in the chamber fluid. This higher pressure closes the suction check valve and opens the discharge check valve, sending the fluid into the discharge line.

During the suction part of the cycle, the piston plunger moves out of the liquid end, increasing the volume of the chamber and lowering the pressure of the chamber fluid. This lower pressure opens the suction check valve and a spring closes the discharge check valve, sending fluid from the suction line into the liquid end.

SECTION 2.0: INSTALLATION OF PUMP AND CONTROLLER

2.1 GENERAL

Always install a pressure regulator in the air/gas supply line for the controller. Also, for the most efficient performance of your pump assembly, we recommend the following:

Figure 3: Solenoid Valve Installation

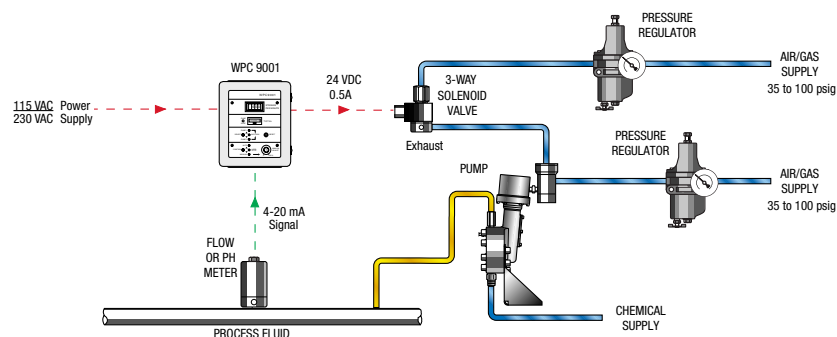

Table 1: Performance Characteristics

Model	Maximum Volume @500PSI GPH / LPH	Volume Per Stroke CC	Stroke Length INCH	Strokes Per Minute (Range)	Max Discharge Pressure PSIG / BARG	Max Air Consumption		Weight lbs/Kg
						@100 PSIG	@6.9 BAR	
						SCF Per Day	SCM Per Day	
WILROY™ 2M	.54 / 2.04	.8	1	1-45	3000 / 207	2100	59	27 / 12.2
WILROY™ 5M	2.25 / 8.51	3.2	1	1-45	3000 / 207	2100	59	27 / 12.2

PUMP PERFORMANCE GRAPHS

The performance graphs, as seen in Figures 4 and 5, show the maximum flow/pressure limit of the pumps. The black line represents the maximum flow capability of the pump (45 SPM @ 100% stroke). The area under the curve represents the entire flow/pressure range for the pumps. As can be seen, the flow rate changes with discharge pressure. The red/gray curve defines the relationship between air/gas supply pressure and discharge pressure. For each discharge pressure there is a minimum air/gas supply pressure required. The performance flow graphs are used as follows:

1) Determine the flow capability of the pump you have selected.

Step 1: First use the performance table (Table 1) to determine your plunger configuration. Make certain the plunger configuration selected satisfies your maximum flow and pressure requirements.

Step 2: Draw a vertical line from your discharge pressure found on the horizontal axis until it intersects the maximum flow line. This point represents the maximum flow at your discharge pressure. Read the value on the left.

2) Determine the stroke rate.

Step 3: Multiply the value determined in step 2 by 3785 cc/gallon. Divide by 60 min./hr and then 45 strokes/min. The resultant is the maximum cc/stroke at the selected discharge pressure.

Step 4: Next, convert your actual flow rate into cc/min (ref. 1 gallon = 3785 cc). Now, divide this number by the answer in step 3 (cc/stroke) in order to get strokes per minute. Your answer is the stroke rate for the pump you selected, when the stroke adjuster is set at 100%. **If this value is close to the extremes (1-45 SPM) you may wish to select the next smaller or larger plunger configuration, in order to allow for a change in the future flow rate.** See section 3.3.2 to set the stroke rate.

3) Determine the stroke adjuster setting.

In order to ensure a relatively constant injection of chemical, you may desire to maximize the stroke rate and decrease the stroke adjuster setting instead of decreasing the stroke rate.

Step 5: The following settings will produce approximately the same flow rate. Scale the stroke rate and stroke adjuster settings according to the table below.

STROKE RATE (SPM)	STROKE ADJUSTER SETTING
10	100%
20	50%
40	25%

4) Determine the air pressure necessary to provide the desired pump discharge pressure.

Step 6: Always add 200 PSI to your discharge pressure in order to ensure positive injection. Find the discharge pressure on the horizontal axis and follow it up to the red/gray curve. At that point, read your air/gas pressure requirements on the right axis in PSIG.

Example:

Application: .95 gph @ 1500 psi

Step 1: The selection from Table 1 is a Wilroy™ 5M

Step 2: In Figure 5, follow 1500 psig up to the max flow curve and read over on the left axis. The answer is 2.01 gph.

Step 3: From step 2, convert maximum flow to cc/stroke.

$$2.01 \frac{\text{gallons}}{\text{hr}} \times \frac{3785 \text{ cc}}{\text{gallon}} \times \frac{1 \text{ hr}}{60 \text{ min}} \times \frac{1 \text{ min}}{45 \text{ stroke}} = 2.82 \frac{\text{cc}}{\text{stroke}}$$

Step 4: Convert your actual flow to cc/min.

$$.95 \frac{\text{gallon}}{\text{hour}} \times \frac{3785 \text{ cc}}{\text{gallon}} \times \frac{1 \text{ hr}}{60 \text{ min}} = 59.9 \frac{\text{cc}}{\text{min}}$$

Now divide 59.9 cc/min by the answer in step 3.

$$59.9 \frac{\text{cc}}{\text{min.}} \times \frac{1}{2.82} \frac{\text{stroke}}{\text{cc}} = 21 \frac{\text{strokes}}{\text{min.}}$$

Step 5: We can alternatively set the stroke rate to 42 and the stroke adjuster to 50%.

Step 6: The required air/gas supply pressure can be read off the graph by first adding 200 psi to the 1500 psi discharge pressure. Then locate 1700 psi on the discharge pressure axis and follow it up until it intersects the red/gray line. Now, follow this point to the air/gas supply pressure axis on the right and you will find that 62 psig air/gas pressure is necessary to operate the pump.

Figure 4: Flow Performance Graph for Wilroy™ 2M

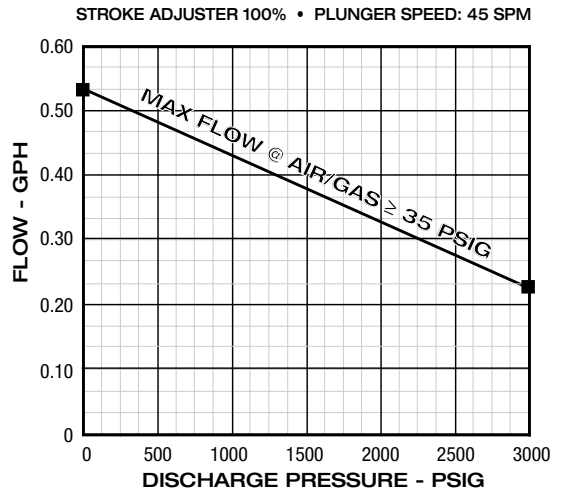
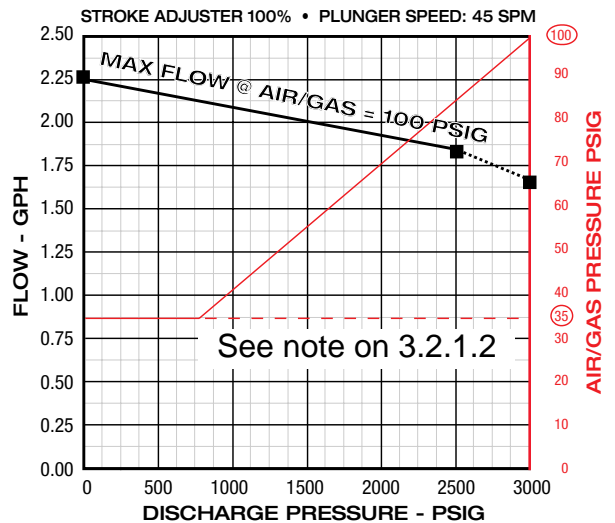

Figure 5: Flow Performance Graph for Wilroy™ 5M



- A dryer and a dump valve in the air/gas supply line to remove any moisture from the supply air/gas.
- Isolation valves (ball type) on inlet and discharge lines of the pump and in the air/gas supply line to simplify maintenance.
- A check valve where the pump discharge line joins the main process line to prevent process fluid back flow.
- An inlet filter, with filtration approximately 25 microns, on pump suction line.
- A flow meter or a rate setting gauge in the suction line or process fluid discharge line, if you need precise flow rate adjustment or recording.

2.2 PUMP MOUNTING

Support the pump firmly in a level position on a solid, vibration-free foundation, preferably with the base above the floor level to protect the pump from wash downs and to provide easier access for service. Position the pump assembly with enough space around it to allow easy access to all components for maintenance. Install the assembly with the pump inlet/suction check valve pointing straight down. The pump will not work as efficiently in any other position since the inlet/suction check valve has no spring. The Wilroy base is provided with mounting holes to accommodate anchor bolts. Refer to Figure 6 for mounting hole dimensions.

Figure 6
Mounting Hole Dimensions - Dimensions in inches [mm]

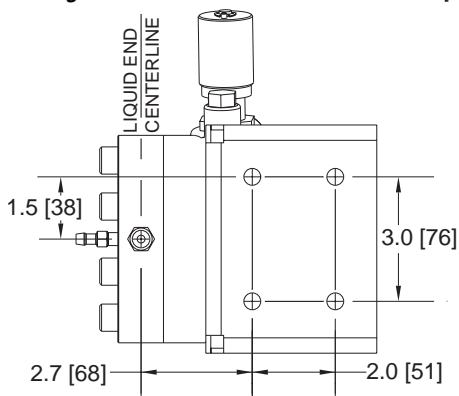

2.3 TYPICAL INSTALLATION

A typical Wilroy™ pump installation is shown in Figure 7. The key ingredients for a successful installation are: 1) Clean, dry regulated air for the controller; 2) A flooded inlet supply; 3) An inlet filter; 4) A rate setting gauge; 5) A line check valve at the point of injection; 6) Isolation valves for maintenance on each component.

2.4 CHEMICAL SUPPLY RESERVOIR

Position the chemical supply reservoir so that the liquid level will not be less than six inches above the inlet check valve (flooded suction). The reservoir can not be located at a height above the inlet check valve greater than 41.5 feet (12.6 m) of water. This corresponds to 18 psig (1.2 barg), which is the operational pressure limit of the stroke adjuster. We do not recommend using the pumps in a suction lift position since they were not designed for such operation.

2.5 RELIEF VALVE

A safety relief valve is not necessary if the downstream piping can withstand the pressure setting of the internal relief valve. When the system pressure reaches the setting of the internal relief valve, the valve will open, causing hydraulic oil to be bypassed into the reservoir, instead of into the liquid end. As a result, chemical will not be pumped into the piping. The relief valve is factory set at 3000 psi (207 bar), so the piping must be able to withstand this pressure. If a different pressure is desired, see section 3.3.3 to adjust the relief valve.

SECTION 3.0: STARTUP, OPERATION, SHUTDOWN, AND STORAGE

3.1 GENERAL

While these procedures for startup, operation, shutdown, and storage are simple, following them carefully and correctly will improve the performance and increase the life of your pump assembly.



CAUTION: To avoid damaging the controller valve stem, do not make a habit of turning the pump ON and OFF with the stroke rate control. Use the recommended ball valve in the air/gas supply line.

3.2 STARTUP

3.2.1 Air/Gas Supply

Before starting up your pump assembly, make sure that the primary air/gas supply, compressor, tank of gas, or other source, is turned OFF. Also, set the pressure regulator(s) to ZERO pressure.

3.2.1.1 Supply Pressure

In order to achieve maximum discharge pressure, the controller must be supplied with air/gas at 100 psi (6.9 bar).

3.2.1.2 Supply Piping

Since supplying the proper air volume to the pump is critical for its operation, avoid long runs of small diameter tubing, as follows:

- Locate the main air/gas supply header as close to the pump as possible.
- Use no more than five feet of 1/4" tubing to supply air/gas to the controller.
- Always locate the controller on the pump.
- If a solenoid valve controls the pump, locate it no more than two feet away and use 1/2" tubing to supply air/gas to the pump.

Note: In order to achieve discharge pressures greater than 2500 psi (172 bar) on the 1/2" plunger pump, it is essential that the air is supplied with 1/2" tubing (I.D.) and that all fittings are 1/2" fittings.

Furthermore, the air pressure can not drop below 100 psi (6.9 bar) as the pump cycles.

Figure 7
Typical Installation

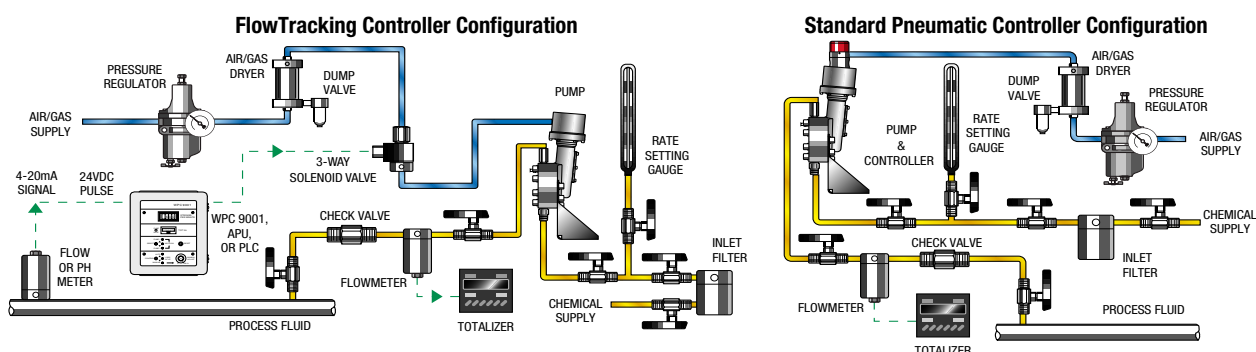

3.2.2 Pump Startup

These startup procedures will produce a flow rate close to what you want. For a more precise flow rate, monitor the pump with a flow meter while making the final adjustment.

1. Mount the pump securely using bolts or studs through the (4) 7/16" holes provided in the bottom of the base. Mount the pump to rigid structure or bracket to insure minimum vibration and maximum rigidity.
2. Remove the reservoir breather plug from the top of the pump reservoir (Fig. 24, item 120). Fill the pump reservoir with the appropriate oil, as specified in section 1.2.2.1. The oil fill level is approximately 3/8" below the top of the oil fill hole. This 3/8" allows for expansion of the oil at higher temperatures. If you overfill, oil may escape out through the breather vent. If you experience this, lower the oil level by removing one of the two drain plugs located at the bottom of the pump. The pump should be checked at regular intervals to insure proper oil levels.
3. Insure all check valve connections and the bleeder port on the liquid end are securely tightened. Use proper methods for sealing the NPT connections. The bleeder port does not require additional sealing compounds.
4. Connect the suction and discharge piping to the pump. Install with recommended components such as strainers, relief valves, air dryer, etc. A flooded suction is recommended (the process fluid tank level is above the level of the liquid end). The discharge check valve is equipped with a back pressure spring that will hold approximately 75 psi (5.2 bar). This spring prevents free flow of the process fluid through the pump. A flooded suction line will not free flow through the pump.
5. Do not run the pump without chemical in the piping system and liquid end. You can damage the diaphragm if the internal relief valve for the pump is set above 3500 psi (241 bar) and there is no chemical in the liquid end.

6. Open the valve from the tank to fill the piping system with process fluid. You can place a short piece of Tygon tubing on the barbed bleeder plug to re-direct chemical into a safe reservoir containment area. Carefully open the bleeder plug on the front of the liquid end to allow trapped air to evacuate from the process side piping. Close the bleeder plug once all air has been evacuated from the liquid end and a steady stream of chemical is flowing from the bleeder plug.



Caution: Contact with the process chemical can be hazardous. Be aware of the characteristics of the chemicals you are handling and use proper safety measures to insure proper handling is achieved.

7. It is recommended that an air dryer and a shutoff valve be installed in the pneumatic supply line to the Mark XIIA controller. Close the shutoff valve and connect the supply to the proper inlet supply port on the controller. Insure all connections are tight. Leaky connections can cause the controller not to function at low supply pressures.
8. On the pump, turn the stroke adjustment knob from its current setting to 0% capacity setting. Each full revolution is 10% adjustment.
9. Turn the air/gas source to ON and open the shutoff valve supplying the controller. The controller will begin to cycle. Due to differing supply pressures, the black knob on the top of the controller might have to be adjusted to read 100 at 45 strokes per minute (SPM). Set the knob at 100. Check the stroke rate and verify that you are achieving 45 SPM. If not, rotate the knob until the rate is 45 SPM and then loosen the set screw on the black knob and lock it in place at 100. **NOTE: The controller will not operate properly if it is set at a stroke rate greater than 45 SPM.**
10. The pump will begin to cycle after the controller supply is opened. Leave the controller at the 100 setting and let the pump cycle for 5-10 minutes. Gradually increase the pump's stroke adjuster from 0% capacity setting to

50% and then to 100%. Make certain there are no closed valves in the discharge piping or any obstructions in the line. The pump's internal relief valve is set at the factory for 3000 psi (207 bar), so any valves that are closed can cause the system to be pressurized to that level. A total system relief valve is also recommended to insure safety and minimize system pressure spikes. Monitor the flow rate of the pump to deliver the proper amount of chemical to your process. Adjust either the stroke rate on the controller or the % capacity adjustment on the pump to achieve the desired flow rate for your process. Maintain tank levels to insure that the liquid end will always have process fluid in the liquid end. Running the pump dry may cause the diaphragm to rupture prematurely.

11. The #6-32 x 1" long set screw at the end of the adjustment knob is a stroke-locking device. Once the desired flow rate is achieved, tighten the set screw to lock the knob into position. Only a minimal amount of tension is required to hold the knob in position

3.3 OPERATION

3.3.1 Bleeder Plug

Bleed the liquid end first. To bleed air trapped in the pump chamber, turn the bleeder plug CCW about a quarter turn. When the liquid is flowing steadily with each pump stroke from the end of the bleeder plug, turn it CW until the flow stops. It is best to close the bleeder plug when the pump is discharging and before the suction stroke.

NOTE: To catch the escaping liquid, slip a length of 1/4" plastic or rubber tubing over the hose barb of the bleeder plug.



Caution: Contact with the process chemical can be hazardous. Be aware of the characteristics of the chemicals you are handling and use proper safety measures to insure proper handling is achieved.

3.3.2 Stroke Rate

Set the operating stroke rate as follows:

1. Set the stroke rate knob to a mark on the scale that will produce a stroke rate close to the one you want. Keep in mind that the scale reading is only an approximate percent indication of the actual rate; generally the pump maximum stroke rate will be set at 100 on the scale. **NOTE: At the ZERO setting on the controller stroke rate scale, the pump will not stroke, but as you rotate the knob toward 100, the rate will increase to the maximum setting, which should correspond to 45 strokes per minute.**



CAUTION: To prevent damage to the pump when you clean it, be sure to use a solvent compatible with the metered fluid that will not damage the pump seals. For a recommended solvent, contact your Williams distributor or Milton Roy Company.

- To set the stroke rate correctly, you must time the exhausts as they leave the bottom of the controller.
2. Count the number of pump strokes during a one minute interval, using a timer such as a stop watch to determine the actual stroke rate.
 3. Adjust the knob to correct the stroke rate as needed. Confirm by timing the stroke rate.
 4. Repeat the above steps until you get the correct stroke rate. **EXAMPLE:** To get a stroke rate of 22 strokes per minute, set the knob to 50 which should produce approximately 25 strokes per minute. Then reduce the rate by resetting the knob to 48. If this produces 21 strokes a minute, move the knob to 49, which should be very close to the 22 strokes per minute you want. Confirm the rate by timing it.

3.3.3 Internal Relief Valve Adjustment

Set the internal relief valve as follows:

1. You must have a gauge and a shutoff valve in the discharge line to set the internal relief valve.
2. Remove the relief valve cover plug located directly below the capacity stroke adjuster. (See item 360, Fig. 24)
3. Using an Allen wrench, turn the relief valve adjustment screw counterclockwise (CCW) 3-4 complete turns.
4. Close the shutoff valve in the discharge line.
5. The pressure in the discharge line will rise until it reaches a maximum pressure noted on the gauge.
6. Turn the adjustment screw CCW to decrease pressure or clockwise (CW) to increase pressure.
7. Once the desired pressure is achieved, replace the relief valve cover plug to keep any oil from leaking from the pump.

3.4 SHUTDOWN AND STORAGE

To shut down the pump assembly, set the pressure regulator(s) to ZERO, and turn the air/gas supply to OFF.

To store the pump assembly or if it will not be used for a long time, do the following:

1. Remove pump from the system.
2. Flush out the pump chamber and check valves with water or solvent; drain and then blow the pump dry with compressed air.

CAUTION: To prevent damage to the pump when you clean it, be sure to use a solvent compatible with the metered fluid that will not damage the pump seals. For a recommended solvent, contact your Williams distributor or Milton Roy Company.

3. Cap off the suction and discharge check valve ports.
4. You may leave the pump and controller assembled, but make sure to store them in a dry, protected place.

SECTION 4.0: MAINTENANCE

4.1 GENERAL

This section contains procedures for disassembly and assembly of the controller, pump, and check valves, plus procedures for preventive and corrective maintenance. To maintain the reliability, durability, and performance of your pump assembly and related components, it is essential to follow these procedures exactly and carefully.

For consistent, reliable performance, replace any O-rings, U-cups, or other seals that you remove. Order replacement seal kits with detailed instructions from your Williams distributor or Milton Roy Company. Whenever you disconnect any air/gas or fluid piping, cover all open ports in the pump assembly to prevent dirt from entering.

4.2 DISASSEMBLY AND ASSEMBLY

4.2.1 Required Tools and Materials

Necessary tools will vary by pump assembly model but the following are typical:

- Adjustable wrench: 12"
- Open-end wrenches: various sizes
- Hex wrenches: 1/16", 7/64", 1/8", 9/64", 3/16", and 5/32", 1/4", 3/8"
- Socket wrenches: various sizes with 2" extension
- Flat-blade Screwdrivers: 1/8" (2 required) and 1/4"
- Brass or plastic O-ring pick (1)
- Torque wrench (15 in-lb to 122 in-lb range)
- Bench vise
- Silicone grease, (Williams G321M4), or synthetic grease (Williams GS102149)
- PTFE pipe thread tape
- Thread sealing compound
- O-ring lubricant

NOTE: See 4.3 Preventive Maintenance for inspection and replacement of parts identified throughout these procedures.

4.2.2 Mark XIIA Controller

Refer to the Mark XIIA Controller Parts List. To disassemble, do the following:

1. Remove red cap. (Fig. 8)



Figure 8

2. The Mark XIIA has (4) four socket head cap screws holding the controller together. Use a 5/32" hex wrench to remove. Separate upper valve body from the lower section. (Fig. 9 & 10)



Figure 9



Figure 10

3. Lift off the upper body and diaphragm. Lift out the inner diaphragm assembly. Set aside. (Fig. 11 & 12)



Figure 11



Figure 12

4. Lift out the spool spring. (Fig. 13)



Fig. 13

5. Turn lower controller body upside down. Use a 3/16" hex wrench to unscrew bottom plug. Remove the bottom plug, lower spring and pilot plug. (Fig. 14 & 15)



Fig. 14



Fig. 15

6. Return controller body as before and unscrew lower seat with a 3/16" hex wrench. Remove lower seat. (Fig. 16 & 17)



Fig. 16



Fig. 17

7. To disassemble the inner diaphragm and spool assembly, first remove outer sleeve and mid ring by sliding past the diaphragms towards the upper seat. (Fig. 18, 19 & 20)



Figure 18



Figure 19



Figure 20

Use a small screw driver or hex wrench placed through the inner spacer holes and with a 9/16" wrench unscrew the upper seat and lower diaphragm. (Fig. 21)



Figure 21

Place the top diaphragm stop (and inner sleeve with screw driver/hex wrench) into a soft jaw vice with a vee notch. Lightly clamp top diaphragm stop.

Unscrew inner sleeve. (Fig. 22)



Figure 22

Remove the mid diaphragm from the top diaphragm stop. (Fig. 23)



Figure 23

Remove the lower diaphragm from the upper seat. (Fig. 24)



Figure 24

8. Clean all metal parts. Inspect and or replace all three diaphragms. To reassemble, push the mid diaphragm onto the top diaphragm stop. Push the lower diaphragm onto the upper seat. Thread the inner spacer onto these (2) two diaphragm assemblies. With a screw driver and 9/16" wrench, tighten securely, but *not* enough to pucker the diaphragms. Install the mid ring, counter bore first, onto the diaphragm assembly past the lower diaphragm and then past the mid diaphragm. Some maneuvering of the diaphragms will be needed. Install the outer sleeve by sliding past the lower diaphragm. Ensure the narrow seat on the sleeve goes against the mid diaphragm and the wider seat is against the lower diaphragm. Some maneuvering of the lower diaphragm will also be needed. The inner assembly is now complete. (Fig. 25 & 26)

9. To install the inner assembly into the lower controller body, be sure to reinstall the lower seat and spool spring. Make sure the capillary holes in



Figure 26

the upper diaphragm, the mid ring and the mid diaphragm are in line with the capillary hole of the lower body. Use a small awl or hex wrench to thread together. Install (1) one of the (4) body screws from the under side through the loose parts and through the top diaphragm. Now remove the awl and place on top of the assembly the upper controller body. Insure its capillary hole is inline with the others. Loosely thread together the (1) one body screw. Install remaining (3) three screws and torque all to 28-32 inch pounds (3.2-3.6 N-m).

4.2.3 Liquid End

Refer to Figure 27 for the following procedure. The liquid end is disassembled as follows:

1. Using a 3/16" hex wrench, remove both of the two drain plugs (Fig. 28, item 150) at the bottom of the Wilroy™ pump, and drain the pump of all oil.
2. Using the appropriate wrenches, remove the inlet check valve (500), reducer bushing (495) if applicable, the discharge check valve (450), and the bleeder plug (460). Note: The reducer bushing is **not** used on the Wilroy™ 5M.



Figure 25

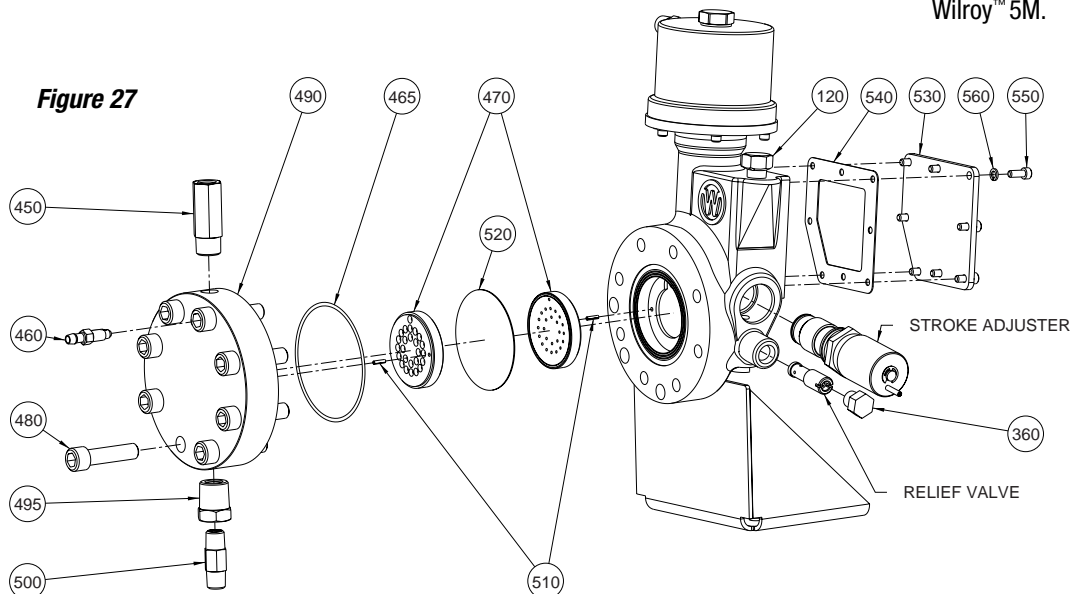
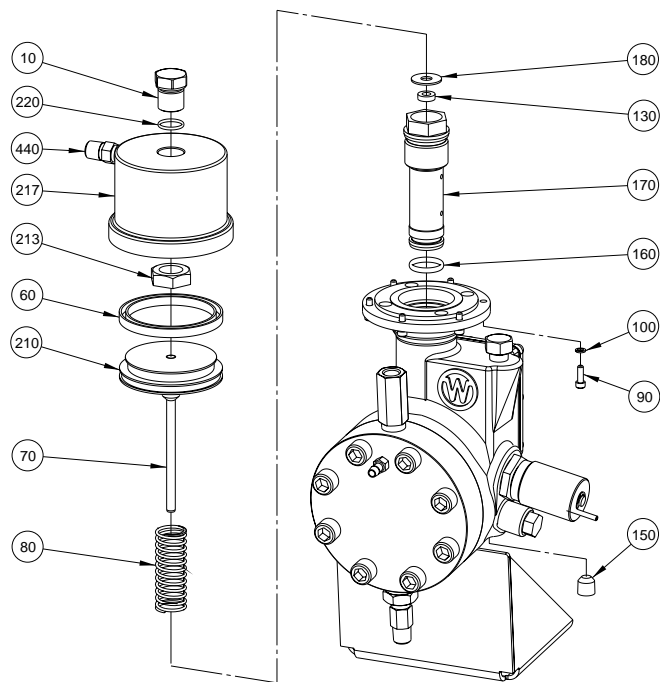

Figure 28



- Using a 3/8" hex wrench, remove the 8 bolts (480) which clamp the faceplate (490) to the pump.
- Remove the contour plates (470), the O-ring (465), and the diaphragm (520). Do not remove the spring pins (510), which will remain attached to the contour plates.
- Clean all components with an appropriate solvent. Contact your Williams distributor or Milton Roy Company for a recommended solvent. Inspect all the parts and replace them if they are worn. **Note: The diaphragm (520) must be replaced each time the liquid end is removed.**

Reassemble the liquid end as follows:

- Insert the first contour plate (470) into the Wilroy™ housing, being sure that the spring pin (510) inserts into the guide hole in the housing. The contour plate should be flush with the housing.
- Lay the diaphragm (520) in the recessed groove of the housing, using some grease to hold it in place.
- Insert the second contour plate (470) into the faceplate (490), being sure that the spring pin (510) inserts into the guide hole in the faceplate. The contour plate should be flush with the faceplate.
- Insert the O-ring (465) into the faceplate, using some grease to hold it in place.

- Align the faceplate (490) so that the bleeder plug hole is oriented toward the top of the pump. Carefully align the faceplate with the bolt holes, being sure that the O-ring and diaphragm remain in their grooves. Insert the bolts (480) and tighten them to a torque of 60 ft-lbs (81 N-m). Be sure to use an alternating tightening pattern when torquing the bolts.
- Install the discharge check valve (450), reducer bushing (495) if applicable, and the inlet check valve (500), being sure to apply thread sealing compound **AND** PTFE pipe thread tape to all connections. Make sure that the end of the inlet check valve with the internal hex is screwed into the faceplate (or reducer bushing, if applicable).
- Insert the bleeder plug (460) into the hole in the faceplate and tighten it snugly with a wrench.
- Insert the drain plugs (150) into the housing, using thread sealing compound. Discard the old oil and fill the pump with the oil specified in section 1.2.2.1.
- Refer to sections 3.2 and 3.3 for the appropriate startup and operation procedures.

4.2.4 Motor Cylinder

Refer to Figure 28 for the following procedure. Disassemble the motor cylinder as follows:

- Using a 9/64" hex wrench, remove the 6 screws (90) and washers (100) which secure the motor cylinder (217).
- With the screws removed, all of the following components are loose—do not disassemble any subassemblies unless otherwise stated. Remove the motor cylinder subassembly—consisting of components 10, 220, 440, 217 and 213. Remove the piston/plunger subassembly—consisting of components 60, 210 and 70. Remove the u-cup seal (60) from the piston/plunger subassembly. Remove the motor cylinder spring (80). Remove the washer (180), which sits in the upper recess of the bore cartridge.
- Using a 1-1/8" socket wrench, remove the bore cartridge subassembly—consisting of components 130, 170 and 160. Remove the O-ring (160) from the bore cartridge. Do not remove the seal (130), which is pressed into the bore cartridge (170). This is an unpressurized splash seal and requires a special tool to insert it.
- Clean all components with an appropriate solvent. Contact your Williams distributor or Milton Roy Company for a recommended solvent. Inspect all the parts and replace them if they are worn.

Reassemble the motor cylinder as follows:

- Slide the O-ring (160) over the bore cartridge (170) into its groove. Apply O-ring lubricant (or equivalent grease) to the outside surface of the O-ring.
- Insert the bore cartridge subassembly—consisting of components 130, 170 and 160—into the Wilroy™ housing and tighten, using a 1-1/8" socket torque wrench, to 25 ft-lb (34 N-m).
- If the pump was drained of oil, it is **CRITICAL** that it be refilled at this step. Insert the drain plug (150) into the housing, using thread sealing compound. Discard the old oil and fill the pump with the oil specified in section 1.2.2.1.
- Insert the washer (180) followed by the spring (80) into the recess of the bore cartridge.

5. Slide the u-cup seal (60) into the groove of the piston (210), making sure that the u-cup is pointing away from the shaft of the plunger (70). Apply silicone grease (Williams G321M1 or equivalent) to the outside surface of the u-cup seal and to the inside surface of the motor cylinder (217).
6. Insert the piston/plunger subassembly into the bore cartridge.
7. Slide the motor cylinder subassembly—consisting of components 10, 220, 440, 217 and 213—over the piston/plunger subassembly and attach it to the Wilroy™ housing using the 6 screws (90) and washers (100).
8. Refer to sections 3.2 and 3.3 for the appropriate startup and operation procedures.

4.2.5 Stroke Adjuster

Refer to Figure 29 for the following procedure. Disassemble the stroke adjuster as follows:

1. Using a 3/16" hex wrench, remove the drain plugs (Fig. 28, item 150) at the bottom of the Wilroy™ pump, and drain the pump of all oil.
2. Using a 1/16" hex wrench, remove the set-screw (350) from the stroke adjuster knob (310). Remove the e-clip (330). Unscrew and remove the stroke adjuster knob.
3. Using a 1/16" hex wrench, remove the set-screw (320) from the stroke adjuster body (260). Then remove the control rod subassembly—consisting of components 225 (if applicable), 355 and 340—do not disassemble any subassemblies unless otherwise stated.

NOTE: The sleeve (225) is not used on the Wilroy™ 5M. Remove the O-ring (355) from the control rod.

4. Using a 1-1/4" deep socket wrench, unscrew the stroke adjuster body subassembly—consisting of components 250, 265, 280, 260 and 300—and remove it. The washer (230) may stick inside the Wilroy™ housing—verify that it is also removed. If the piston (240) and spring (270) are still inside the stroke adjuster body, remove them at this time. Remove the O-rings (250 and 280) from the stroke adjuster body subassembly.
5. Clean all components with an appropriate solvent. Contact your Williams distributor or Milton Roy Company for a recommended solvent. Inspect all the parts and replace them if they are worn.

Reassemble the stroke adjuster as follows:

1. Slide the O-rings (250 and 280) over the stroke adjuster body assembly into their appropriate grooves. Slide the piston (240) into the bore insert (265).
2. Apply O-ring lubricant (or equivalent grease) to the outside surface of the O-rings (250 and 280). Insert the washer (230) into the recess of the bore insert (265), using some grease to hold it in place.
3. Carefully screw the stroke adjuster body assembly into the Wilroy™ housing, so that the washer (230) does not fall out of the recess in the bore insert (265). There should be a gap of approximately .030 inches between the Wilroy™

housing and the hex portion of the stroke adjuster body. If the gap is greater than this, the washer probably fell out of the recess in the bore insert. If this is the case, remove the stroke adjuster body assembly and reinsert the washer into the recess of the bore insert.

4. Using a 1-1/4" deep socket torque wrench, tighten the stroke adjuster body assembly to 25 ft-lbs (34 N·m). DO NOT OVERTIGHTEN, as this may cause binding of the internal components.
5. Insert the spring (270) through the stroke adjuster body (260) and slide it over the piston (240).
6. Slide the O-ring (355) into the groove of the control rod (340). Apply O-ring lube (or equivalent grease) to the outside surface of the O-ring.
7. Insert the control rod subassembly into the stroke adjuster body.
8. Apply a removable thread-locking adhesive to the set-screw (320). With the control rod assembly fully inserted, thread the set-screw into the stroke adjuster body (see Figure 30).

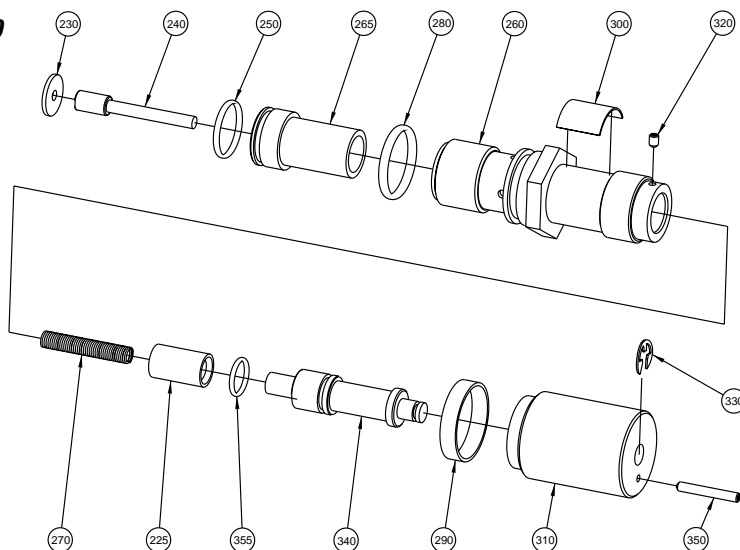

Figure 30

Screw the set-screw into the stroke adjuster body until it contacts the control rod (340), then back the set-screw out 1/2 of a turn.

9. Screw the knob assembly—consisting of components 290 and 310—onto the stroke adjuster body (260) until the knob bottoms out. There should be a gap of approximately .080 inches between the calibration ring and the hex portion of the stroke adjuster body.
10. Press the e-clip (330) into the groove of the control rod (340) so as to retain the knob (310).

Figure 29



11. Adjust the knob (310) to the desired setting and insert the set-screw (350) into the knob. Thread the set-screw into the knob until it contacts the stroke adjuster body (260). Tighten the set-screw so as to lock the knob in place.
12. Insert the drain plugs (150) into the housing, using thread sealing compound. Discard the old oil and fill the pump with the oil specified in section 1.2.2.1.
13. Refer to sections 3.2 and 3.3 for the appropriate startup and operation procedures.

4.2.6 Relief Valve

Refer to Figure 31 for the following procedure. Disassemble the relief valve as follows:

1. Using a 3/16" hex wrench, remove the drain plugs (Fig. 28, item 150) at the bottom of the Wilroy™ pump, and drain the pump of all oil.
2. Remove the plug (Fig. 27, item 360). Using a flat head screwdriver, unscrew and remove the relief valve subassembly.
3. Using a 5/32" hex wrench, remove the adjustment screw (380) and dump out the spring (390), ball holder (400) and ball (410). The ball will probably stick inside the ball holder—if this is the case, keep the parts together. Do not separate the sleeve (370) from the seat (420).
4. Remove the O-ring (430) from the other end of the cartridge.
5. Clean all components with an appropriate solvent. Contact your Williams distributor or Milton Roy Company for a recommended solvent. Inspect all the parts and replace them if they are worn.

Figure 31

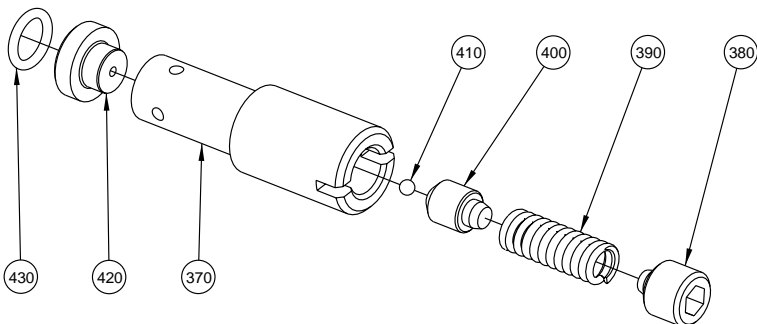

Reassemble the relief valve as follows:

1. Insert the ball (410) into the ball holder (400). Slide the ball holder onto the spring (390).
2. While holding the spring vertical such that the ball and ball holder are on top, slide the sleeve subassembly—consisting of components 420 and 370—over the ball holder and spring.
3. Flip this subassembly over and insert the adjustment screw (380). Using a 5/32" hex wrench, tighten the adjustment screw until it clears the notch in the sleeve.
4. Insert the O-ring (430) into the end of the seat (420).
5. Insert the relief valve subassembly into the pump, using a flat head screwdriver to tighten it snugly.
6. Insert the drain plugs (150) into the housing, using thread sealing compound. Discard the old oil and fill the pump with the oil specified in section 1.2.2.1.
7. Refer to sections 3.2 and 3.3 for the appropriate startup and operation procedures.

4.2.7 Reservoir

Refer to Figure 27 for the following procedure. Clean the reservoir as follows:

1. There are 2 drain plugs at the bottom of the Wilroy™ pump, remove both drain plugs (150) and drain the pump of all oil.
2. Using a 5/32" hex wrench, remove the 8 screws (550) and washers (560). Remove the cover plate (530) and gasket (540).
3. Clean all components with an appropriate solvent. Contact your Williams distributor or Milton Roy Company for a recommended solvent. Inspect all the parts and replace them if they are worn.

Reassemble the reservoir as follows:

1. Affix the cover plate (530) and gasket (540) to the Wilroy™ pump with the 8 screws (550) and washers (560). Tighten securely, but *not* enough to pucker the gasket.
2. Insert the drain plugs (150) into the housing, using thread sealing compound. Discard the old oil and fill the pump with the oil specified in section 1.2.2.1.
3. Refer to sections 3.2 and 3.3 for the appropriate startup and operation procedures.

4.2.8 Discharge Check Valve

Refer to the appropriate parts list.

Disassemble the check valve as follows:

1. Clamp the check valve body in the vise.
2. Using a 3/16" hex wrench, unscrew and remove the retainer.
3. Remove the body from the vise and dump out the spring, ball seat, ball, sleeve, and O-ring. (Fig. 32)



Figure 32

4. Remove the O-ring from the sleeve.
5. Inspect all the parts and replace them if they are worn.

Reassemble the check valve as follows:

1. Put the O-ring in the sleeve and drop the sleeve, O-ring first, into the body.
2. Drop the ball into the body.
3. Put the small end of the spring in the spring cavity on the wide end (**not** the slotted end) of the ball seat. Drop the two parts, ball seat first, into the body.
4. Drop the retainer, spring cavity first, into the body and use a 3/16" hex wrench to torque to 230-240 in-lbs (26-27 N-m)

4.2.9 Suction Check Valves

Although there are two sizes of check valves with minor construction differences, they are disassembled and reassembled in the same way. The procedures describe the differences. Refer to the appropriate parts list. Disassemble the check valve as follows:

1. Clamp the check valve body in the vise.
2. Use the appropriate hex wrench to unscrew and remove the retainer. (Fig. 33)



Figure 33

3. Remove the body from the vise and dump out the ball, sleeve, and O-ring.
NOTE: The Wilroy™ 2M does not have an O-ring. On the Wilroy™ 5M, remove the O-ring from the sleeve. (Fig. 34)



Figure 34

Reassemble the check valve as follows:

1. On the Wilroy™ 5M, put the O-ring in the sleeve and drop the sleeve, O-ring first, into the body. On the Wilroy™ 2M, drop the sleeve, the end with a shoulder first, into the body.
2. Drop the ball into the body.
3. Use the appropriate hex wrench to screw the retainer into the body. Tighten securely.

4.3 PREVENTATIVE MAINTENANCE

4.3.1 Periodic Maintenance

4.3.1.1 Once a week:

Perform the following procedures:

1. Check for process fluid leaking from the plumbing.
2. Check for process fluid leaking from the liquid end of the pump.
3. Check for air/gas leaks.
4. Check for loose fittings and screws.

4.3.1.2 At least every three months:

Inspect the oil level in the pump. Add oil, if necessary, in order to maintain an oil level approximately 3/8" below the top of the oil fill hole. Do not overfill, or oil will pump through the breather port.

4.3.1.3 At least every six months:

Remove the motor cylinder. Clean, inspect and re-grease the components as directed in section 4.2.4. Replace worn parts. It is not necessary to remove the bore cartridge at this time.

4.3.1.4 At least every twelve months:

Perform the following procedures:

1. Disassemble and inspect the pump inlet and outlet check valves, as directed in sections 4.2.8 and 4.2.9. Replace worn parts.
2. Disassemble the liquid end and replace the diaphragm, as directed in section 4.2.3. Discard the oil and replace with new oil.

4.3.1.5 At least every two years:

Perform a complete tear down and rebuild of the pump, as directed in sections 4.2.3 through 4.2.9. Replace worn parts.

4.3.2 Cleaning and Lubrication:

Whenever the pump assembly is disassembled: Clean all inside and outside surfaces with an approved solvent, and blow them dry with compressed air.



CAUTION: To prevent damage to the pump when you clean it, use a solvent that is compatible with the process fluid and that will not damage pump seals. Contact your Williams distributor or Milton Roy Company for a recommended solvent.

4.4 TROUBLESHOOTING

4.4.1 Proper Pump Use

When a pump is either not working or working incorrectly, the trouble can be in two basic areas: the pneumatic or the fluid ends of the pump. However, since factors other than the pump can affect its operation, first check that the pump is being used properly. To help you determine this, use the following checklist:

1. Is the air/gas supply available in sufficient volume and at the proper pressure?
2. Is the air/gas supply of clean instrument quality, not dirty or wet?
3. Is a pressure regulator in use to maintain a constant air supply?
4. Is the tube or pipe size of the air/gas supply line correct for your pump model?
5. Is the pump correct for the nature and characteristics of the material(s) it handles: composition, viscosity, necessary line pressure, etc.?
6. Is the process fluid container—drum, day tank or large storage tank—clean and free of contaminants?
7. Is the filtration adequate? Disassemble and inspect.
8. Is the size of the process fluid line correct for the pump?
9. Is the distance between the pump and supply air/gas correct?
10. Is the pump operating within acceptable minimum and maximum temperature limits?
11. Is the proper cleaning fluid being used to flush out the pump?
12. Is there a current and accurate service/maintenance/breakdown record for the pump?

4.4.2 Troubleshooting Guide

The Troubleshooting Guide on the following pages identifies the most common problems, their possible causes, and corrective action for each problem.

TROUBLESHOOTING GUIDE

PROBLEM	POSSIBLE CAUSE(S)	CORRECTIVE ACTION
CONTROLLER NOT OSCILLATING	<ul style="list-style-type: none"> Foreign material in controller 	<ul style="list-style-type: none"> Put finger over exhaust port; alternately seal & vent port to clear exhaust valve.
	<ul style="list-style-type: none"> No air/gas supply 	<ul style="list-style-type: none"> Connect a separate pressure gauge to the port on the controller which is opposite the supply line; verify that the required supply pressure is attained.
	<ul style="list-style-type: none"> Supply pressure too high or too low 	<ul style="list-style-type: none"> Reset regulator to proper pressure.
	<ul style="list-style-type: none"> Too much pressure drop in air/gas line 	<ul style="list-style-type: none"> Increase the connecting tube size and/or clean the air lines.
	<ul style="list-style-type: none"> Stroke rate valve open too much 	<ul style="list-style-type: none"> Disconnect air/gas supply. Rotate stroke rate knob CCW to peg, wait 5 seconds, & rotate knob CW until it stops. DO NOT FORCE KNOB. Reconnect supply & rotate knob CCW until oscillations start. Adjust stroke rate to 45 strokes per minute; loosen the set screw on the knob, rotate knob CCW to the peg, & tighten the set screw.
	<ul style="list-style-type: none"> Leak between valve body & controller body 	<ul style="list-style-type: none"> Loosen; then retighten the connection between valve & controller body. If dirty, disassemble, wipe clean and reassemble.
	<ul style="list-style-type: none"> Continuous air flow from controller exhaust port (Pilot plug not seating properly) 	<ul style="list-style-type: none"> Inspect the controller & replace damaged lower seat and pilot plug.
	<ul style="list-style-type: none"> Air flowing from equalizer hole on the side of the controller body 	<ul style="list-style-type: none"> Inspect & replace ruptured or improperly seated seals. Put finger over exhaust port; alternately seal & vent port to clear exhaust valve.
	<ul style="list-style-type: none"> Broken pilot plug, exhaust spring, or spool return spring 	<ul style="list-style-type: none"> Inspect and replace damaged parts.
	<ul style="list-style-type: none"> Excessive water in controller 	<ul style="list-style-type: none"> Install an air/gas dryer or separator in supply line.
PLUNGER NOT STROKING	<ul style="list-style-type: none"> Controller control knob set at ZERO 	<ul style="list-style-type: none"> Turn knob to proper setting on dial.
	<ul style="list-style-type: none"> Air/gas supply turned OFF 	<ul style="list-style-type: none"> Open valve to allow air supply to flow to controller.
	<ul style="list-style-type: none"> Broken motor return spring 	<ul style="list-style-type: none"> Inspect and replace return spring.
	<ul style="list-style-type: none"> Air/gas supply pressure too low to overcome process line pressure 	<ul style="list-style-type: none"> Increase supply pressure to controller.
	<ul style="list-style-type: none"> Discharge or suction line plugged 	<ul style="list-style-type: none"> Clean the lines.
	<ul style="list-style-type: none"> Air/gas flow to controller too low (controller locked up and will not cycle) 	<ul style="list-style-type: none"> Install a larger capacity regulator or supply line. <u>Vent</u> supply side of controller and try to start pump at slowest speed; increase speed slowly if controller starts to cycle.
	<ul style="list-style-type: none"> Motor cylinder-air piston blow-by 	<ul style="list-style-type: none"> Check piston seal; replace as needed. Check motor cylinder surface for damage from dirt or sand; install clean filters on bottom of cylinder faceplate. Replace cylinder if necessary.

PROBLEM	POSSIBLE CAUSE(S)	CORRECTIVE ACTION
LOW PUMP OUTPUT	<ul style="list-style-type: none"> • Viscosity of the chemical being pumped too high. 	<ul style="list-style-type: none"> • Review and enlarge size of supply and discharge lines to improve flow of chemical.
	<ul style="list-style-type: none"> • Pump mounted too high to suck adequate supply of chemical to fluid cylinder 	<ul style="list-style-type: none"> • Remount pump to create a flooded suction (six inch minimum).
	<ul style="list-style-type: none"> • Pump appears sluggish in stroking. Piston not returning all the way. 	<ul style="list-style-type: none"> • Remount pump as close to controller as possible to allow the controller to exhaust quickly. Check for ice in exhaust port.
	<ul style="list-style-type: none"> • Suction lift condition inadequate. 	<ul style="list-style-type: none"> • Change tank elevation to get flooded suction if change not possible, add foot valve at end of suction line, and increase suction line diameter.
	<ul style="list-style-type: none"> • Blocked suction filter 	<ul style="list-style-type: none"> • Clean or replace filter element.
	<ul style="list-style-type: none"> • Supply and discharge lines too small. See pump sluggish 	<ul style="list-style-type: none"> • Install correct tubing size.
	<ul style="list-style-type: none"> • Erratic controller operation 	<ul style="list-style-type: none"> • Rebuild, clean and lubricate controller; add air inlet filter or air/gas dryer.
	<ul style="list-style-type: none"> • Check valves leaking or contaminated. Loss of pump capacity 	<ul style="list-style-type: none"> • Rebuild, replace damaged parts.
NO PUMP DISCHARGE	<ul style="list-style-type: none"> • Suction check valve or discharge check valve not seating 	<ul style="list-style-type: none"> • Clean or replace check valves.
	<ul style="list-style-type: none"> • Suction or discharge line clogged 	<ul style="list-style-type: none"> • Inspect line for closed connections or valves.
	<ul style="list-style-type: none"> • Air entering suction line 	<ul style="list-style-type: none"> • Tighten fittings; Inspect and replace sealants.
	<ul style="list-style-type: none"> • Pump vapor locked 	<ul style="list-style-type: none"> • Open bleeder plug and prime pump.

**SECTION 5.0
REPAIR KIT AND CONVERSION KIT
ORDERING REFERENCE**

5.1 REPAIR KIT

Repair kits for the Wilroy™ pumps and MK X11A controller are tabulated below.

PART	PARTS LIST	REPAIR KIT
MK - X11A	PL - MK - X11A	OS72
WILROY™ 2M	WILROY™ RK	RKWRA1250
WILROY™ 5M	WILROY™ RK	RKWRA1500

5.2 CONVERSION KIT

One of the features of the Wilroy™ pump is the ability to convert it from a 1/4" plunger (Wilroy™ 2M) to a 1/2" plunger (Wilroy™ 5M) with relative ease.

The conversion kit ordering information is detailed below.

PUMP	PARTS LIST	CONVERSION KIT
FROM 2M TO 5M	WILROY™ CK	CKWRA1500
FROM 5M TO 2M	WILROY™ CK	CKWRA1250

**SECTION 6.0
LIMITED WARRANTY**

The Milton Roy Company ("Company") warrants that its pumping products will be free from defects in title, and so far as of its own manufacture, will be free from defects in materials and workmanship for a period of thirty six months from shipment by the Company. The Company additionally warrants that all of its other products, including actuators, will be free from defects in title, and so far as of its own manufacture, will be free from defects in materials and workmanship for a period of twelve months from shipment by the Company. The Company will, as its option, repair or replace its products provided the Company's inspection reveals the products to have been defective or nonconforming within the terms of this warranty. This warranty is expressly conditioned upon the following: (a) proper installation, maintenance, and use under the Company specified service conditions, (b) prompt notice of nonconformance or defect, (c) the Company's prior written authorization for return, (d) the products being returned to the Company, or at the Company's discretion, to a Factory Authorized Service Center, all at no cost to the Company. The Company will deliver repaired or replacement products Ex Works its factory or Factory Authorized Service Center. Products not of the Company's manufacture are warranted only to the extent provided by the original manufacturer. The company shall not be liable for damage of any kind resulting from erosive, corrosive or other harmful action of any liquids, gases, or any other substance handled by the Company's products.

THE FOREGOING IS IN LIEU OF ALL OTHER WARRANTIES, OBLIGATIONS, OR LIABILITIES, WHETHER EXPRESSED, IMPLIED, OR STATUTORY, INCLUDING ANY WARRANTY OF MERCHANTABILITY OR FITNESS FOR A PARTICULAR PURPOSE.

UNDER NO CIRCUMSTANCES SHALL THE COMPANY BE LIABLE FOR ANY INCIDENTAL, CONSEQUENTIAL, OR SPECIAL DAMAGES, LOSSES, OR EXPENSES ARISING FROM THIS CONTRACT, ITS PERFORMANCE, OR IN CONNECTION WITH THE USE OF, OR INABILITY TO USE THE COMPANY'S PRODUCTS.

The liability of the Company in respect of all damages, losses, costs or expenses, whether suffered or incurred by the Purchaser or any third party arising in any manner or incident related to this contract or the performance hereunder, shall be limited in the aggregate to the actual price paid by the Purchaser to the Company.

NOTES



www.williamspumps.com

PENNSYLVANIA: 201 Ivyland Road • Ivyland, PA 18974 USA • (800) 235-3421 • (215) 293-0415 • Fax: (215) 293-0498 • E-mail: info@williamspumps.com

CANADA: 9357 45th Avenue • Edmonton, Alberta T6E 5Z7 Canada • (780) 434-9471 • Fax: (780) 435-6560 • E-mail: edmonton@williamspumps.com

SINGAPORE: 18 Bedok Road South • Singapore 469276 • (65) 242-9182 • Fax: (65) 243-4249 • E-mail: singapore@williamspumps.com